

07 | STANCHIONS

Stanchions allow you the ability to implement a fourth and fifth axis to your application. Within this section there are many types of stanchions that allow versatility when designing your project and modularity when utilizing your project. Anything from single or double shaft bases, blank mounting or pre-drilled mounting plates, to single or double mounting blocks are available.

The Horizontal Quick Clamp stanchion, a different style of stanchion, allows you to retain the modularity you get with TSLOTS extrusions. By utilizing our tubes and solid rounds you can create precise positioning with our stanchions. Position of camera equipment and light sources, even positioning for actuators or sensors, has never been easier.

STANCHION ADVANTAGES

1. Adjustable in X, Y and Z axis when used with TSLOTS
2. Bolts directly to TSLOTS extrusions
3. Choose from aluminum or steel tubes for stanchion posts

Stanchions

STANCHIONS - Single Shaft Base



ITEM #	DESCRIPTION
659012	10 S 1" Diameter Single Shaft Base (10S) (25S)
659013	15 S 1" Diameter Single Shaft Base (15S)
659016	15 S 1.5" Diameter Single Shaft Base (15S)
659018	15 S 2" Diameter Single Shaft Base (15S)

RECOMMENDED FASTENERS

QTY	ITEM#
(4)	651117 (for 659012)
(4)	651205 (for 659013)
(4)	651482 (for 659016)
(4)	651482 (for 659018)

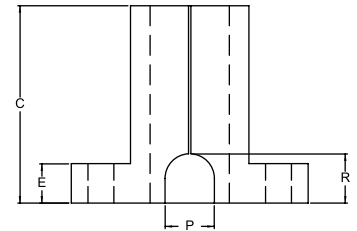
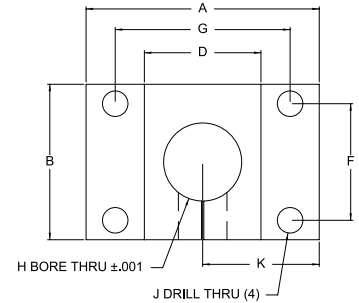

ITEM #	LBS	A	B	C	D	E	F	G	H	J	K	P	R
659012	.705	3.000	2.125	2.500	1.500	.500	1.000	2.250	1.004	.257	1.500	.625	.625
659013	.700	3.000	2.125	2.500	1.500	.500	1.500	2.250	1.004	.328	1.500	.625	.625
659016	1.355	3.875	2.500	3.000	2.250	.750	1.500	3.000	1.505	.328	1.937	.875	.875
659018	2.220	4.750	3.500	3.500	2.750	.750	1.500	3.750	2.005	.328	2.375	1.250	.750

STANCHIONS - Double Shaft Base



ITEM #	DESCRIPTION
659014	10 S 1" Diameter Double Shaft Base (10S) (25S)
659015	15 S 1" Diameter Double Shaft Base (15S)
659017	15 S 1.5" Diameter Double Shaft Base (15S)
659020	15 S 2" Diameter Double Shaft Base (15S)

RECOMMENDED FASTENERS

QTY	ITEM#	&	QTY	ITEM#
(4)	651117	(2)	651483	(for 659014)
(4)	651205	(2)	651484	(for 659015)
(4)	651482	(2)	651485	(for 659017)
(4)	651482	(2)	651486	(for 659020)

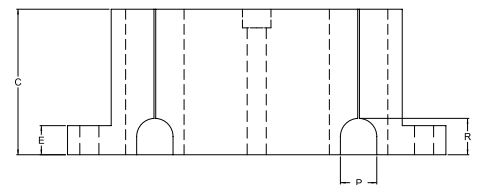
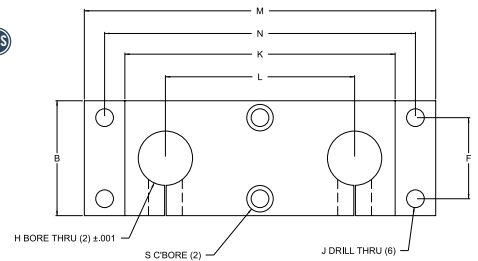

ITEM #	LBS	B	C	E	F	H	J	K	L	M	N	P	R	S
659014	2.230	2.000	2.500	.500	1.000	1.004	.257	5.000	3.500	6.500	5.750	.620	.625	.406 x .26 Deep
659015	2.225	2.000	2.500	.500	1.500	1.004	.328	5.000	3.500	6.500	5.750	.620	.625	.50 x .32 Deep
659017	3.590	2.500	3.000	.750	1.500	1.505	.328	6.125	3.875	7.750	6.875	.875	.825	.50 x .32 Deep
659020	6.030	3.500	3.500	.750	1.500	2.005	.328	7.500	4.750	9.500	8.500	1.250	.750	.50 x .32 Deep

STANCHIONS - Single Shaft Blank Mounting Plate 10S 15S 25S 40S



ITEM #	DESCRIPTION
659023	1" Diameter Single Shaft Blank Mounting Plate
659026	1.5" Diameter Single Shaft Blank Mounting Plate
659028	2" Diameter Single Shaft Blank Mounting Plate

ITEM #	LBS	A	B	C	D	E	F
659023	.965	4.500	2.000	3.562	1.004	1.250	1.000
659026	2.515	6.500	3.000	5.125	1.505	1.500	1.500
659028	5.295	7.750	4.000	6.125	2.005	2.000	2.000

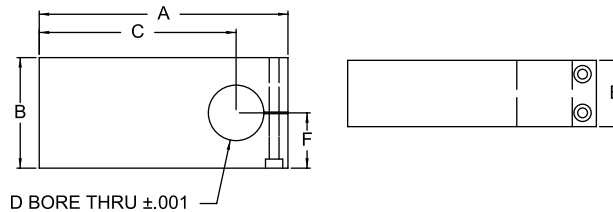

STANCHIONS - Single Shaft Pre-Drilled Mounting Plate



ITEM #	DESCRIPTION
659024	10 S 1" Diameter Single Shaft Pre-Drilled Mounting Plate 10S 25S
659025	15 S 1" Diameter Single Pre-Drilled Mounting Plate 15S
659027	15 S 1.5" Diameter Single Shaft Pre-Drilled Mounting Plate 15S
659029	15 S 2" Diameter Single Shaft Pre-Drilled Mounting Plate 15S

ITEM #	LBS	A	B	C	D	E	F	G	H	J	K	L
659024	.940	4.500	2.000	1.000	1.000	3.560	2.062	4@.257	1.004	1.250	N/A	1.000
659025	.935	4.500	2.000	1.500	1.500	3.562	1.562	4@.328	1.004	1.250	N/A	1.000
659027	2.460	6.500	3.000	1.500	1.500	5.125	2.875	4@.328	1.505	1.500	N/A	1.500
659029	5.210	7.750	4.000	1.500	1.500	6.125	2.375	6@.328	2.005	2.000	1.500	2.000

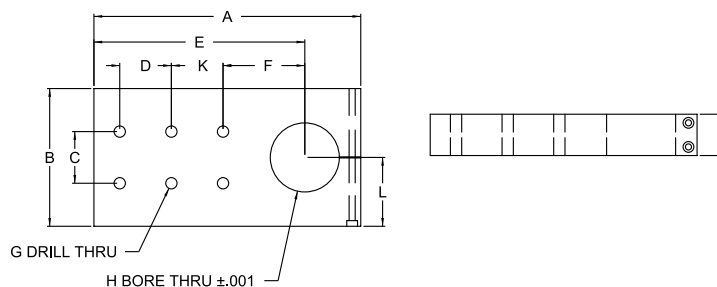

Stanchions

STANCHIONS - Single Shaft Mounting Block 10S 15S 25S 40S



ITEM # DESCRIPTION
659019 10 S 1" Quick Cross Clamp

ITEM #	LBS	A	B	C	D	E	F
659019	.825	3.375	1.500	2.375	1.000	1.004	.750

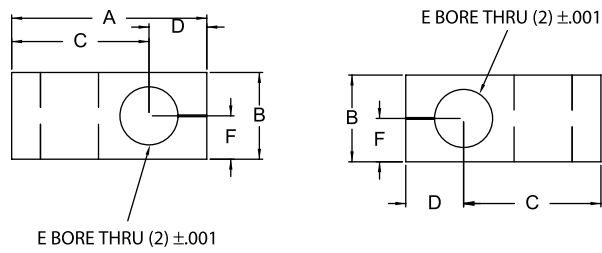

STANCHIONS - Single Shaft Mounting Block 10S 15S 25S 40S



ITEM # DESCRIPTION
659030 1" Diameter Single Shaft Mounting Plate

ITEM #	LBS	A	B	C	D	E	F	G	H	J
659030	.600	2.000	1.000	1.004	1.500	5/16-18X.500	N/A	N/A	.250	N/A

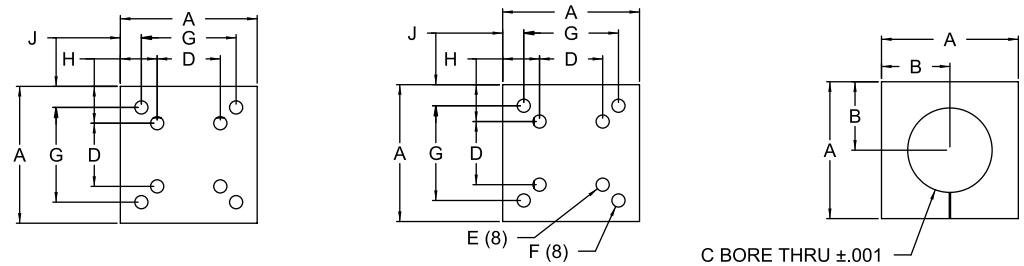

07:04

STANCHIONS - Single Horizontal Base



ITEM #	DESCRIPTION
659044	10 S 1" Single Horizontal Base (10S) (25S)
659045	15 S 1" Single Horizontal Base (15S)
659046	15 S 1.5" Single Horizontal Base (15S)
659047	15 S 2" Single Horizontal Base (15S)

RECOMMENDED FASTENERS

QTY	ITEM#
(2)	651117 (for 659044)
(2)	651205 (for 659045)
(2)	651482 (for 659046)
(2)	651487 (for 651487)

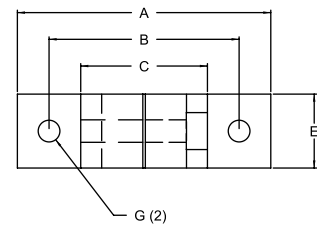
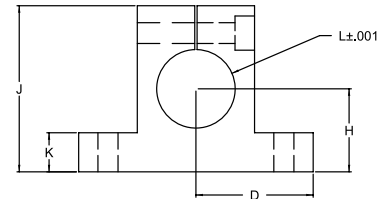

ITEM #	LBS	A	B	C	D	E	G	H	J	K	L
659044	.268	3.000	2.250	1.500	1.500	1.000	.257 THRU	1.062	2.125	.500	1.004
659045	.259	3.000	2.250	1.500	1.500	1.000	.328 THRU	1.062	2.125	.500	1.004
659046	1.253	3.875	3.000	2.250	1.937	1.250	.328 THRU	1.125	2.500	.750	1.505
659047	1.074	4.750	3.750	2.750	2.375	1.500	.328 THRU	1.625	3.500	1.000	2.005

STANCHIONS - Double Horizontal Base

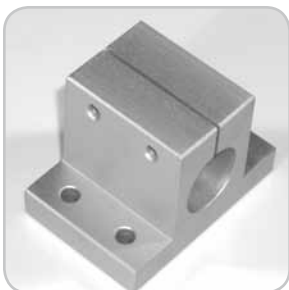

ITEM #	DESCRIPTION
659049	10 S 1" Double Horizontal Base (10S) (25S)
659050	15 S 1" Double Horizontal Base (15S)
659051	15 S 1.5" Double Horizontal Base (15S)
659052	15 S 2" Double Horizontal Base (15S)

RECOMMENDED FASTENERS

QTY	ITEM#
(4)	651117 (for 659049)
(4)	651205 (for 659050)
(4)	651482 (for 659051)
(4)	651487 (for 659052)

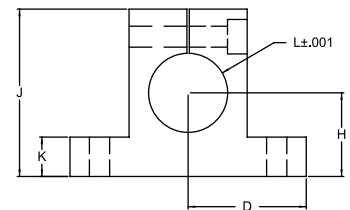
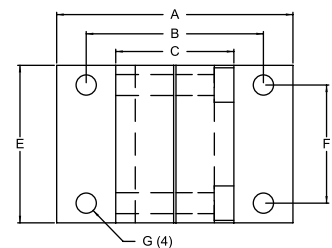



ITEM #	LBS	A	B	C	K	E	F	G	H	J	K	L
659049	.575	3.000	2.250	1.500	1.500	2.000	1.000	.257 THRU	1.062	2.125	.500	1.004
659050	.568	3.000	2.250	1.500	1.500	2.000	1.500	.328 THRU	1.062	2.125	.500	1.004
659051	1.210	3.875	3.000	2.250	1.937	2.500	1.500	.328 THRU	1.125	2.500	.750	1.505
659052	1.906	4.750	3.750	2.750	2.375	3.500	1.500	.328 THRU	1.625	3.500	1.000	2.005

Stanchions

STANCHIONS - Horizontal Quick Clamp



ITEM #	DESCRIPTION
659021	10 S 1" Horizontal Quick Clamp  
659022	15 S 1" Horizontal Quick Clamp 

RECOMMENDED FASTENERS

QTY	ITEM#
(2)	651117 (for 659021)
(2)	651205 (for 659022)

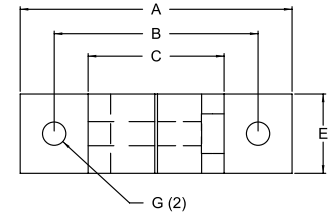
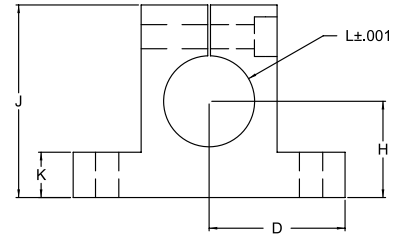

ITEM #	LBS	A	B	C	D	E	G	H	J	K	L
659021	.294	3.000	2.250	1.500	1.500	1.000	.257 THRU	1.062	2.125	.500	1.004
659022	.294	3.000	2.250	1.500	1.500	1.000	.328 THRU	1.062	2.125	.500	1.004

STANCHIONS - Cross Clamp



ITEM #	DESCRIPTION
659031	1" Diameter Stanchion Cross Clamp
659033	1.5" Diameter Stanchion Cross Clamp
659035	2" Diameter Stanchion Cross Clamp

ITEM #	LBS	A	B	C	D	E	F
659031	.925	3.125	2.000	2.125	1.000	1.004	1.000
659033	1.665	4.125	2.500	2.875	1.250	1.505	1.250
659035	3.620	5.500	3.500	3.875	1.750	2.005	1.625

